

# A gene for speed? The evolution and function of $\alpha$ -actinin-3

Daniel G. MacArthur and Kathryn N. North\*

## Summary

The  $\alpha$ -actinins are an ancient family of actin-binding proteins that play structural and regulatory roles in cytoskeletal organisation and muscle contraction.  $\alpha$ -actinin-3 is the most-highly specialised of the four mammalian  $\alpha$ -actinins, with its expression restricted largely to fast glycolytic fibres in skeletal muscle. Intriguingly, a significant proportion (~18%) of the human population is totally deficient in  $\alpha$ -actinin-3 due to homozygosity for a premature stop codon polymorphism (R577X) in the *ACTN3* gene. Recent work in our laboratory has revealed a strong association between R577X genotype and performance in a variety of athletic endeavours. We are currently exploring the function and evolutionary history of the *ACTN3* gene and other  $\alpha$ -actinin family members. The  $\alpha$ -actinin family provides a fascinating case study in molecular evolution, illustrating phenomena such as functional redundancy in duplicate genes, the evolution of protein function, and the action of natural selection during recent human evolution.

*BioEssays* 26:786–795, 2004.

© 2004 Wiley Periodicals, Inc.

## Introduction

The  $\alpha$ -actinins are a highly conserved family of actin-binding proteins belonging to the spectrin protein superfamily, which also contains the spectrins and dystrophin.<sup>(1)</sup>  $\alpha$ -actinin isoforms have been identified and characterised both genetically and biochemically from a wide range of taxa, including protists,<sup>(2)</sup> invertebrates,<sup>(3,4)</sup> birds,<sup>(5)</sup> and mammals.<sup>(6,7)</sup> During evolution, gene duplication and alternative splicing have resulted in the generation of considerable functional diversity within the  $\alpha$ -actinin family. This diversity is most marked in mammals, where four separate  $\alpha$ -actinin-encoding genes produce at least six distinct protein products, each with a unique tissue-expression profile.<sup>(6–10)</sup> Based on biochemical properties, expression patterns and subcellular localisation, these proteins can be categorised into two broad groups: non-muscle cytoskeletal (calcium-sensitive) isoforms, and muscle sarcomeric (calcium-insensitive) isoforms.<sup>(1)</sup>

Our group has a particular interest in the two sarcomeric  $\alpha$ -actinin isoforms in humans ( $\alpha$ -actinin-2 and  $\alpha$ -actinin-3), which

are encoded by separate genes (*ACTN2* and *ACTN3*, respectively).<sup>(6)</sup> In skeletal muscle, these  $\alpha$ -actinins constitute the predominant protein component of the sarcomeric Z line, where they form a lattice structure that anchors together actin-containing thin filaments and stabilises the muscle contractile apparatus<sup>(11)</sup> (Fig. 1). In addition to their mechanical role, the sarcomeric  $\alpha$ -actinins interact with proteins involved in a variety of signalling and metabolic pathways. The expression pattern of the two sarcomeric  $\alpha$ -actinins has diverged during mammalian evolution, with  $\alpha$ -actinin-2 becoming the predominant isoform in heart and oxidative skeletal muscle fibres, while  $\alpha$ -actinin-3 expression is restricted largely to fast glycolytic skeletal muscle fibres.<sup>(10)</sup>

Intriguingly, our group has demonstrated that a significant proportion of humans in a variety of ethnic groups are homozygous for a common polymorphism (R577X) in the *ACTN3* gene, which results in a premature stop codon and creates a null allele.<sup>(12)</sup> The complete deficiency of  $\alpha$ -actinin-3 in 577X homozygotes does not result in a disease phenotype, suggesting that the related sarcomeric isoform  $\alpha$ -actinin-2 can compensate for the absence of  $\alpha$ -actinin-3.<sup>(10)</sup> However, this compensation does not appear to be complete: we have recently demonstrated that the frequency of the 577X null allele is significantly lower in elite sprint and power athletes than in controls, suggesting that  $\alpha$ -actinin-3 is required for optimal muscle performance at high velocity.<sup>(13)</sup> In contrast, a *higher* frequency of the null allele in endurance athletes suggests that this variant may somehow provide an advantage for long-distance performance. We propose that the R577X variant has been maintained in the human population for a significant period of our evolutionary history by balancing selection, and that the increased frequency of this allele in some ethnic groups may have been due to recent population-specific positive selection.

This review will discuss several aspects of the  $\alpha$ -actinin protein family, beginning with an exploration of current information about the functional properties and evolutionary history of  $\alpha$ -actinins throughout the eukaryotes, and leading into a summary of the recent research carried out by our group into the function and recent evolution of  $\alpha$ -actinin-3 in humans.

## Domain structure

Members of the  $\alpha$ -actinin family are characterised by a distinctive domain structure (Fig. 1). All  $\alpha$ -actinins contain an N-terminal actin-binding domain (ABD) comprising two

The Children's Hospital at Westmead, Westmead, Sydney.

\*Correspondence to: Kathryn N. North, The Children's Hospital at Westmead, Clinical Sciences Bldg, Locked Bag 4001, Westmead, Sydney, 2145 NSW, Australia. E-mail: kathryn@chw.edu.au  
DOI 10.1002/bies.20061

Published online in Wiley InterScience (www.interscience.wiley.com).

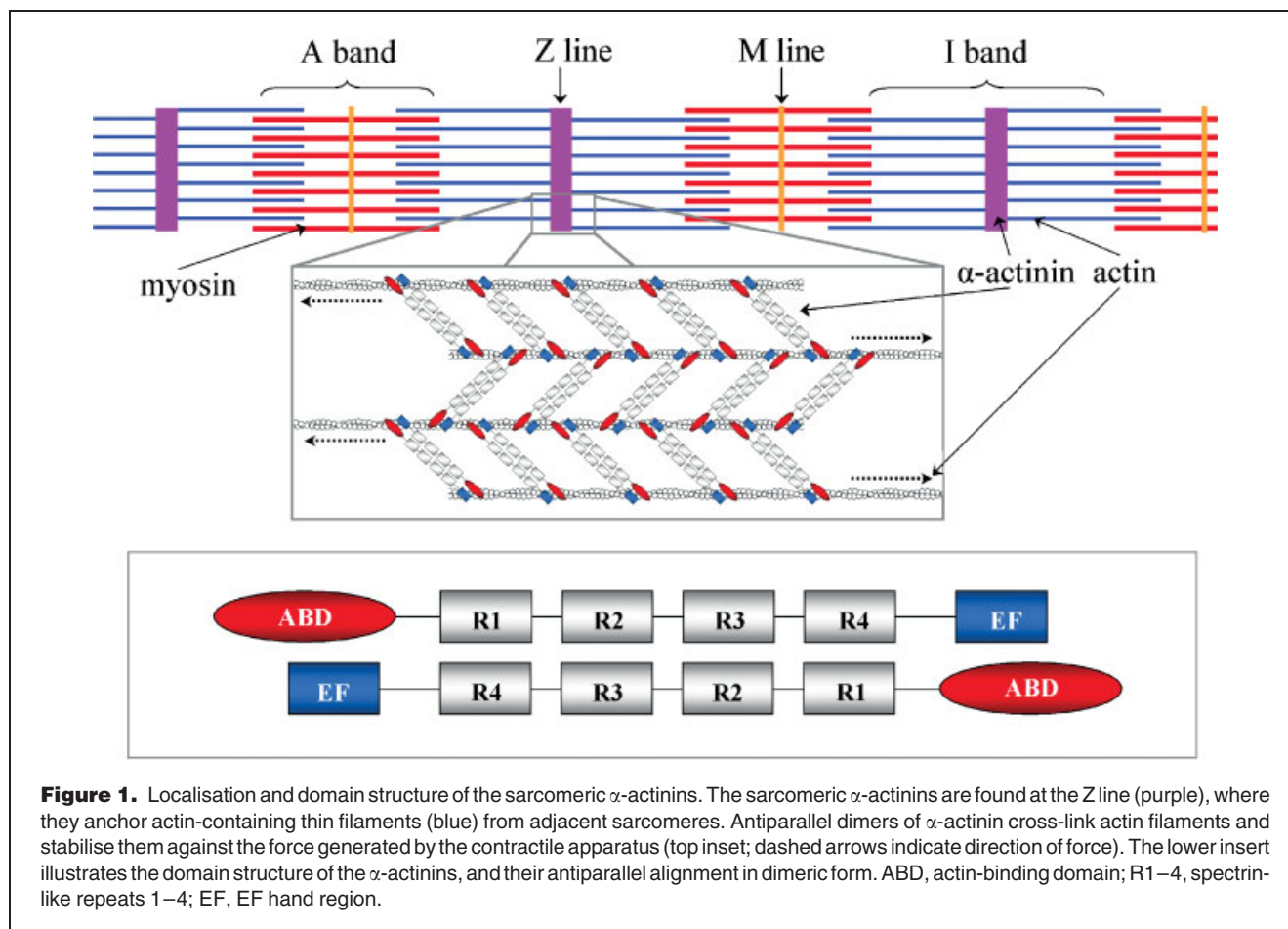

**Figure 1.** Localisation and domain structure of the sarcomeric  $\alpha$ -actinins. The sarcomeric  $\alpha$ -actinins are found at the Z line (purple), where they anchor actin-containing thin filaments (blue) from adjacent sarcomeres. Antiparallel dimers of  $\alpha$ -actinin cross-link actin filaments and stabilise them against the force generated by the contractile apparatus (top inset; dashed arrows indicate direction of force). The lower inset illustrates the domain structure of the  $\alpha$ -actinins, and their antiparallel alignment in dimeric form. ABD, actin-binding domain; R1–4, spectrin-like repeats 1–4; EF, EF hand region.

calponin homology (CH) domains, a central rod domain consisting of spectrin-like repeats (SLRs), and a C-terminal region with similarity to calmodulin, which contains two EF hand (EFh) domains.

The ABDs of all  $\alpha$ -actinins are by far the most-highly conserved regions, reflecting the astonishingly strong evolutionary conservation of their binding target actin.<sup>(14)</sup> The domain architecture of the ABD, which consists of a type 1 and a type 2 CH domain arranged in tandem, is also found in the ABDs of many other proteins, including most members of the spectrin superfamily.<sup>(15)</sup> In all of these proteins, the two CH domains act cooperatively in conferring high-affinity binding to actin.<sup>(15)</sup>

The central rod region of the  $\alpha$ -actinins, which is generally composed of a tandem array of spectrin-like repeat domains, is significantly less conserved than the ABD. The precise number of SLRs within the rod domain has changed during evolution: the  $\alpha$ -actinin-like proteins from the protozoan *Entamoeba histolytica*, the fungus *Schizosaccharomyces pombe* and the parasite *Trichomonas vaginalis* appear to contain one,<sup>(16)</sup> two<sup>(17)</sup> and five<sup>(18)</sup> repeats, respectively, while most remaining  $\alpha$ -actinins, including all known vertebrate

isoforms, contain four classical SLRs. A dramatic expansion in the number of SLRs has occurred during the evolution of other members of the spectrin superfamily, which contain up to 30 SLRs.<sup>(19)</sup> In the  $\alpha$ -actinins, the primary function of the SLRs appears to be protein–protein interaction, both in the formation of dimers and in binding with a variety of structural and signalling proteins.<sup>(20)</sup>

The C-terminal region of the  $\alpha$ -actinins, which contains two EFh domains, is the most-highly characterised site of functional divergence between  $\alpha$ -actinin isoforms. In cytoskeletal (non-muscle) isoforms, the EFh domains bind calcium, which regulates the kinetics of binding to actin<sup>(21)</sup> and other proteins. In contrast, all characterised sarcomeric (smooth and striated muscle) isoforms contain a five amino acid deletion and several substitutions that eliminate their ability to bind calcium.<sup>(2)</sup> Like the SLRs, the EFh region of the  $\alpha$ -actinins plays additional roles in interactions with various proteins, such as titin.<sup>(22)</sup>

### Protein interactions

Many binding partners have been identified for the sarcomeric  $\alpha$ -actinins. A complete catalogue of binding partners falls

outside the scope of this review, but a brief description of the major functional categories helps to illustrate the diverse structural, signalling and, possibly, metabolic roles played by the sarcomeric  $\alpha$ -actinins. It should be noted that very few of the interactions discussed below have been directly confirmed for  $\alpha$ -actinin-3, but rather were characterised using either recombinant  $\alpha$ -actinin-2 or a purified mixture of the two sarcomeric isoforms,  $\alpha$ -actinin-2 and  $\alpha$ -actinin-3. However, given the high degree of sequence identity between the two sarcomeric  $\alpha$ -actinins, it seems likely that many of these interactions apply to both isoforms.

The most-important binding partners of the sarcomeric  $\alpha$ -actinins are themselves: all known  $\alpha$ -actinins form head-to-tail dimers<sup>(1)</sup> through interactions between their spectrin-like repeats.<sup>(23)</sup> The two human sarcomeric  $\alpha$ -actinins are able to form both homodimers and heterodimers with apparently equivalent affinity and stability,<sup>(24)</sup> suggesting strong structural and functional similarity between the two isoforms in addition to their high levels of sequence identity.<sup>(6)</sup> Dimerisation has two important consequences for the function of all  $\alpha$ -actinins: firstly, it creates a long molecule with an ABD at either end, allowing the cross-linking of actin filaments; and, secondly, it brings the C-terminal region of one  $\alpha$ -actinin molecule into close proximity with the N-terminal ABD of its binding partner, allowing regulatory interactions between the two regions (Fig. 1).

The next class of  $\alpha$ -actinin-binding proteins consists of structural proteins of the muscle contractile machinery. The most-well-characterised interaction of the  $\alpha$ -actinins is with the thin filament protein actin,<sup>(25)</sup> but the sarcomeric  $\alpha$ -actinins also bind to the actin cross-linking protein myotilin,<sup>(26)</sup> the massive “sarcomeric ruler” proteins titin<sup>(27)</sup> and nebulin,<sup>(28)</sup> and the thin filament capping protein CapZ.<sup>(29)</sup> In addition, the  $\alpha$ -actinins participate in both of the two major protein complexes linking the sarcomere to the muscle fibre membrane, through interactions with both dystrophin<sup>(30)</sup> and integrin.<sup>(31)</sup>

The  $\alpha$ -actinins also interact with an array of signalling proteins, including the PDZ-LIM domain-containing proteins<sup>(32–36)</sup> and a number of membrane receptors and ion channels, including the adenosine  $A_{2A}$  receptor,<sup>(37)</sup> the NR1 and NR2B subunits of the NMDA glutamate receptor,<sup>(38)</sup> the L-type calcium channel,<sup>(39)</sup> and the Kv1.4 and Kv1.5 potassium channels.<sup>(40)</sup> Both of the skeletal muscle  $\alpha$ -actinins have been shown to interact with members of the calsarcin family,<sup>(41,42)</sup> a group of proteins that localise to the Z line in striated muscle<sup>(41)</sup> and bind to the  $Ca^{2+}$ - and calmodulin-dependent protein phosphatase calcineurin. Calcineurin is an important signalling protein in skeletal muscle, and is thought to play a role in the determination of muscle fibre type<sup>(43)</sup> and in muscle hypertrophy.<sup>(44)</sup>

Finally, the sarcomeric  $\alpha$ -actinins interact with metabolic enzymes, including the glycogenolytic enzyme phosphorylase<sup>(45)</sup> and (as a ternary complex) the enzymes fructose-1,6-bisphosphatase and aldolase.<sup>(46)</sup> The functional significance

of these interactions is unclear. However, the binding of metabolic enzymes to cytoskeletal proteins is a common mechanism of enzyme regulation,<sup>(47)</sup> and it is possible that the tethering of these enzymes at the sarcomeric Z line by  $\alpha$ -actinin contributes to the local availability of metabolites for local energy generation.

The interactions of the  $\alpha$ -actinins with their binding partners are regulated in several ways. The binding of non-muscle  $\alpha$ -actinins to actin appears to be primarily controlled by calcium, the binding of which to the EFh domains in one molecule of an  $\alpha$ -actinin dimer triggers a conformational change that inhibits actin binding by the adjacent ABD of the other molecule.<sup>(21)</sup> Calcium-mediated inhibition of actin binding does not affect the striated and smooth muscle  $\alpha$ -actinin isoforms, due to sequence changes in the EFh region that eliminate their calcium-binding properties.<sup>(2)</sup>

Both sarcomeric and cytoskeletal  $\alpha$ -actinins are regulated by phosphoinositol-4,5-bisphosphate ( $PIP_2$ ), which binds to a region within the ABD.<sup>(48)</sup>  $PIP_2$  increases the affinity of  $\alpha$ -actinin for titin<sup>(49)</sup> and inhibits binding to CapZ,<sup>(29)</sup> while there are contradictory reports on its effects on actin binding.<sup>(50,51)</sup> The  $PIP_2$ -binding site of  $\alpha$ -actinin is located between the ABD and the first spectrin-like repeat and bears recognisable similarity to the target region of titin; in the absence of  $PIP_2$ , this N-terminal region acts as a pseudoligand for the C-terminal titin-binding site of the other  $\alpha$ -actinin molecule in the dimer, sterically blocking the interaction with titin. The binding of  $PIP_2$  to  $\alpha$ -actinin relieves this self-inhibitory binding and triggers a conformational change that allows binding between  $\alpha$ -actinin and titin, and presumably also modifies the binding affinity of  $\alpha$ -actinin for both actin and CapZ.<sup>(49)</sup>

The diverse array of known binding partners for the sarcomeric  $\alpha$ -actinins suggests that these proteins form a hub at the intersection of several important functional pathways in skeletal muscle, helping to maintain the integrity of both the contractile apparatus and the crucial link between the sarcomere and the plasma membrane, and potentially playing important roles in the communication between the sarcomeric machinery and other cellular pathways and in the regulation of skeletal muscle metabolism. The question of how these diverse functional roles may have evolved during the long history of the  $\alpha$ -actinin family is a fascinating and ongoing research interest of our group.

### Evolution of functional diversity in the $\alpha$ -actinin protein family

The  $\alpha$ -actinins are an ancient gene family whose origins substantially preceded the origins of metazoans. A clear  $\alpha$ -actinin homologue has been isolated from the colonial protist *Dictyostelium discoideum*,<sup>(2)</sup> and “ $\alpha$ -actinin-like” proteins have been identified in the fungus *S. pombe*,<sup>(17)</sup> the protozoan *E. histolytica*<sup>(52)</sup> and the parasite *T. vaginalis*.<sup>(18)</sup> There is also some evidence for an  $\alpha$ -actinin-like molecule in the

cyanobacterium *Spirulina platensis*,<sup>(53)</sup> suggesting that the origin of the family may predate even the eukaryote–prokaryote divergence. Amongst metazoans,  $\alpha$ -actinins have been identified and sequenced in the invertebrates *Drosophila melanogaster*<sup>(3)</sup> and *Caenorhabditis elegans*,<sup>(4)</sup> and in a variety of vertebrates including birds,<sup>(5)</sup> rodents,<sup>(54)</sup> and primates.<sup>(6,7)</sup> The presence of complete coding sequences for  $\alpha$ -actinin isoforms in this taxonomically broad set of organisms provides a superb opportunity to explore the evolutionary history of an important protein family.

A phylogenetic tree containing  $\alpha$ -actinin proteins from a group of representative taxa is shown in Fig. 2A. The topological relationships between the vertebrate  $\alpha$ -actinins are somewhat controversial: the tree shown in Fig. 2A differs slightly from that determined by one previous phylogenetic analysis,<sup>(54)</sup> but is supported by a more recent analysis based

on protein sequences from a larger set of taxa<sup>(16)</sup> and by our own phylogenetic analyses (D.M., unpublished data).

The most-immediately apparent feature of the phylogeny is an expansion of the  $\alpha$ -actinin family in vertebrates: the protist *D. discoideum* and the invertebrates *D. melanogaster* and *C. elegans* have only one  $\alpha$ -actinin gene, whereas the  $\alpha$ -actinin genes in all characterised vertebrates fall into four distinct orthologous clusters. All mammals examined closely (humans, mice and rats) contain one representative of each of the four clusters, whereas the chicken, *Gallus gallus*, has  $\alpha$ -actinin-1,  $\alpha$ -actinin-2 and  $\alpha$ -actinin-4 orthologues<sup>(5,55)</sup> but no known  $\alpha$ -actinin-3.

It is possible that the “missing” chicken  $\alpha$ -actinin-3 orthologue is actually present but has not yet been identified, although even a comparatively low-stringency screen of a muscle cDNA library using a non-muscle  $\alpha$ -actinin probe,

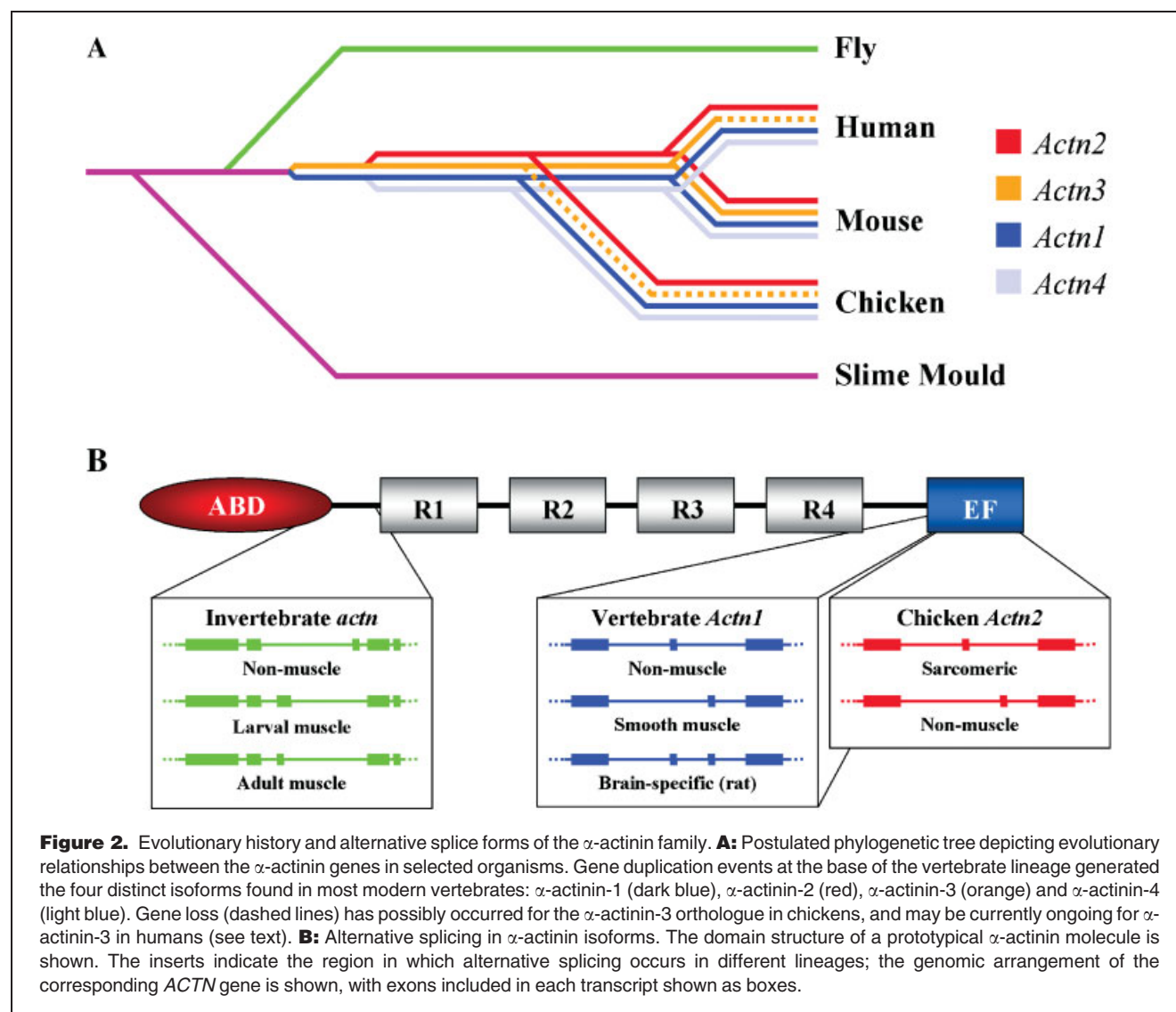



which successfully detected the *ACTN2* isoform, failed to identify any *ACTN3* gene,<sup>(56)</sup> and there are no clear *ACTN3* orthologues present in online chicken EST and genomic DNA databases. There are several possible evolutionary explanations for the absence of chicken *ACTN3*: the duplication that created the *ACTN2* and *ACTN3* genes may have occurred in mammals after their divergence from the avian lineage, or the chicken *ACTN3* homologue may have been lost during evolution. It is also possible that *ACTN3* has an unusual expression pattern in avians, which has resulted in its omission from cDNA and EST libraries—for instance, it could be the poorly characterised embryonic muscle isoform detected by Kobayashi et al.<sup>(57)</sup>

A second important feature of the  $\alpha$ -actinin family is alternative splicing. This occurs in both vertebrates and invertebrates, but affects different regions of the transcript in the two lineages (Fig. 2B). In *Drosophila*, transcripts from the single *actn* gene are spliced to generate three distinct protein isoforms, which differ from one another at the boundary of the ABD and the first spectrin-like repeat. These isoforms are differentially expressed both during development and in adult tissue: one is expressed in adult non-muscle cells, the second in adult fibrillar muscle, and the third in larval muscle and adult supercontractile muscle.<sup>(58)</sup> The phenotypic effects of both hypomorphic<sup>(58)</sup> and null<sup>(59)</sup> alleles of the fly *actn* gene have been characterised: mutant flies show striated muscle defects resulting from severe myofibrillar disruption, but unexpectedly display no obvious non-muscle pathology. It thus appears likely that *Drosophila*  $\alpha$ -actinin performs crucial and non-redundant functions in striated muscle, while its functions in non-muscle cells can be substituted by other actin-binding proteins.<sup>(60)</sup>

At least two of the *Drosophila* splice isoforms have also been annotated in WormBase (<http://www.wormbase.org/>) as being transcribed from the *atn-1* gene<sup>(4)</sup> of *C. elegans*. Interestingly, the alternatively spliced region of the invertebrate  $\alpha$ -actinins falls within an area that has been shown to regulate the phospholipid-dependent interaction between vertebrate  $\alpha$ -actinin isoforms and titin,<sup>(49)</sup> suggesting that the splice isoforms in invertebrates may differ with respect to their titin-binding properties. As yet this possibility has not been explored experimentally.

The functional effects of alternative splicing in the  $\alpha$ -actinins have been better characterised in vertebrates, where splicing occurs in the EF hand-encoding region of several  $\alpha$ -actinin isoforms (Fig. 2B). In most cases, the splicing involves the alternate use of two separate exons, one of which introduces a deletion between the two EF hand domains and thus generates a calcium-insensitive isoform, while the other produces a functional EF hand region and a calcium-sensitive isoform—this has been demonstrated for  $\alpha$ -actinin-1 in chicken<sup>(61)</sup> and rat,<sup>(8)</sup> and appears to occur for  $\alpha$ -actinin-2 in chicken<sup>(56)</sup> but not in mammals. There is also evidence for a brain-specific splice form of rat  $\alpha$ -actinin-1 that incorporates both of the alternative

exons in a single transcript, although the function of the protein encoded by this transcript is unclear.<sup>(9)</sup>

Alternative splicing in the EF hand region must predate the *ACTN* gene expansion in vertebrates, as essentially identical splicing patterns have been observed both in muscle (chicken  $\alpha$ -actinin-2) and non-muscle (vertebrate  $\alpha$ -actinin-1) isoforms. The remaining genes appear to have undergone differential loss of alternatively spliced exons, essentially “fixing” them as either calcium-insensitive sarcomeric forms (mammalian  $\alpha$ -actinin-2 and  $\alpha$ -actinin-3) or calcium-sensitive cytoskeletal proteins (vertebrate  $\alpha$ -actinin-4). This type of differential loss of subfunctions is thought to be a common mechanism for the maintenance of duplicated genes in vertebrates, and allows greater freedom for functional specialisation during subsequent evolution.<sup>(62)</sup>

Gene duplication and alternative splicing have thus resulted in the generation of a variety of functionally distinct  $\alpha$ -actinin isoforms in vertebrates, each of which has a unique pattern of tissue expression and (presumably) a distinct functional role. It is interesting to note, however, that these distinct roles have not prevented gene loss from occurring in both vertebrate and non-vertebrate lineages. For instance, it appears that the sole  $\alpha$ -actinin orthologue identifiable in the fungus *S. pombe* has been lost during the evolution of the fungal species *Saccharomyces cerevisiae*.<sup>(17)</sup> Amongst the vertebrates, the *ACTN3* orthologue that was almost certainly present in the common ancestor of reptiles and mammals may have been lost in the chicken lineage. Intriguingly, a similar process may be occurring independently in humans: we have shown that a null allele of *ACTN3*, which probably arose several hundred thousand years ago, has now reached a high frequency in the general human population. The functional and evolutionary implications of this null allele are a major focus of our research, and will be discussed in the remainder of this review.

### Deficiency of $\alpha$ -actinin-3 in the general population

Given the localisation and evolutionary conservation of the  $\alpha$ -actinins and the phenotypic effects of mutations in sarcomeric  $\alpha$ -actinin genes in non-human organisms and in  $\alpha$ -actinin-interacting genes in humans, *ACTN2* and *ACTN3* both appear to be excellent candidates for genes affected in human muscle disease. These genes and their protein products were thus screened by one of us (K.N.) and her colleagues in patients suffering from a wide range of neuromuscular disorders.

The results of this screening were initially extremely promising, with a number of congenital muscular dystrophy (CMD) patients presenting with a striking deficiency of  $\alpha$ -actinin-3 on both immunohistochemistry and Western blot.<sup>(63)</sup> However, it later became clear that this deficiency was either a secondary phenomenon or completely unrelated to muscle

disease in many patients: linkage analysis ruled out the *ACTN3* gene as the site of causative locus in some  $\alpha$ -actinin-3-deficient patients, and  $\alpha$ -actinin-3 deficiency was demonstrated in patients with a wide variety of forms of muscular dystrophy in whom the causative mutation was known.<sup>(64)</sup>

The lack of any clear correlation between  $\alpha$ -actinin-3 deficiency and particular clinical features was puzzling, but did not rule out the possibility that at least some cases of muscle diseases with  $\alpha$ -actinin-3 deficiency were due to primary mutations in the *ACTN3* gene. With this in mind, we sequenced the entire coding region of the *ACTN3* cDNA from one  $\alpha$ -actinin-3-deficient patient with idiopathic muscle disease, and immediately discovered what appeared to be a primary disease-causing mutation: the patient was homozygous for a premature stop codon mutation (R577X) predicted to prevent synthesis of more than a third of the  $\alpha$ -actinin-3 protein. It seemed likely that this truncation resulted in an unstable protein product that was rapidly degraded, leading to complete  $\alpha$ -actinin-3 deficiency.

Our elation at the apparent discovery of a novel muscle disease gene rapidly turned to confusion. When we sequenced the corresponding exon in the unaffected siblings and parents of the patient, we discovered precisely the same thing: homozygosity for our putative disease mutation. The same genotype was discovered in DNA from several healthy controls—including members of our own research team! It became clear that this variant was not a rare disease-causing mutation, but rather was a benign polymorphism present in a substantial proportion of the healthy population.

We went on to characterise the extent of  $\alpha$ -actinin-3 deficiency by immunohistochemical staining of 267 muscle biopsies with dystrophic, myopathic, neurogenic or normal features.<sup>(12)</sup> A large proportion (19%) of these samples showed  $\alpha$ -actinin-3 deficiency. Homozygosity for the 577X allele was identified in 46 of 48  $\alpha$ -actinin-3-deficient samples; in the remaining two cases, the  $\alpha$ -actinin-3 deficiency was secondary to a pathological loss of fast muscle fibres, in which  $\alpha$ -actinin-3 is expressed. Genotyping of 547 control DNA samples from various ethnic groups revealed homozygosity for the 577X allele in ~15% of samples overall, although with marked variation in frequency amongst different ethnic populations.<sup>(10)</sup> This high allelic frequency clearly demonstrated that the R577X mutation, and consequent absence of  $\alpha$ -actinin-3 protein, represented a non-pathogenic change.

At first glance, the absence of  $\alpha$ -actinin-3 protein from a significant proportion of the general population appears to suggest that  $\alpha$ -actinin-3 is functionally redundant; that is, its absence can be totally compensated for by other proteins. There is an obvious candidate for such a compensating factor:  $\alpha$ -actinin-2, which is highly similar to  $\alpha$ -actinin-3 at the amino acid level (81% identical, 91% similar or identical), demonstrates the same subcellular localisation at the sarcomeric Z line in skeletal muscle fibres, and has an expression pattern

that totally overlaps that of  $\alpha$ -actinin-3.<sup>(10)</sup> It thus appears likely that  $\alpha$ -actinin-2 is the compensatory factor that buffers the phenotypic effects of deficiency of  $\alpha$ -actinin-3, and we are currently in the process of confirming this experimentally.

Despite this apparent compensation, there are hints that possible functional effects of the R577X null allele in humans might warrant further investigation. *ACTN3* has been highly evolutionarily conserved since its divergence from *ACTN2* more than 300 million years ago,<sup>(10)</sup> suggesting that its presence provides some distinct adaptive benefit in most mammals that cannot be compensated for by *ACTN2*. This is certainly true in the mouse, where a subset of fast skeletal muscle fibres express  $\alpha$ -actinin-3 but not  $\alpha$ -actinin-2.<sup>(10)</sup> Although the requirement for  $\alpha$ -actinin-3 may have been lost in the human lineage, it is also plausible that absence of this protein still has subtle functional effects on human muscle function. We thus hypothesised that the R577X polymorphism may be one of the many genetic factors that underlie variation in human athletic performance.

### Association between *ACTN3* genotype and athletic performance

Given the evidence suggesting that  $\alpha$ -actinin-3 performs important functions in fast-type skeletal muscle, it seemed reasonable to predict that there may be subtle differences in skeletal muscle function between humans with different *ACTN3* R577X genotypes. More specifically, we reasoned that if  $\alpha$ -actinin-3 performed some crucial role in fast muscle fibres, it was likely that humans who expressed  $\alpha$ -actinin-3 (those with RR or RX genotypes) would have an advantage over  $\alpha$ -actinin-3-deficient (XX) humans in terms of sprint or power performance. The most-obvious way to test this prediction was to look at a group of humans who engage in some of the most-extreme forms of sprint and endurance performance imaginable—elite athletes.

In collaboration with the Australian Institute of Sport (AIS), we obtained DNA samples from more than 400 elite (national level) Australian athletes competing in a wide variety of sports, ranging from swimming to cross-country skiing. Given the predictions outlined above, we were particularly interested in athletes who competed in sprint or power events, so we asked the AIS to categorise our athlete cohort according to their position on the sprint/endurance spectrum. A total of 107 athletes were classed as specialist power/sprint athletes, while another 194 were classified as specialist endurance athletes. For comparison, we gathered DNA from a cohort of 436 unrelated controls. Because the frequency of the 577X allele is known to differ significantly between ethnic groups,<sup>(10)</sup> we selected only athletes and controls identified as being of white European ancestry.

The results of this study<sup>(13)</sup> are summarised in Fig. 3. Briefly, we observed a significantly lower frequency of the 577XX ( $\alpha$ -actinin-3-deficient) genotype in sprint/power

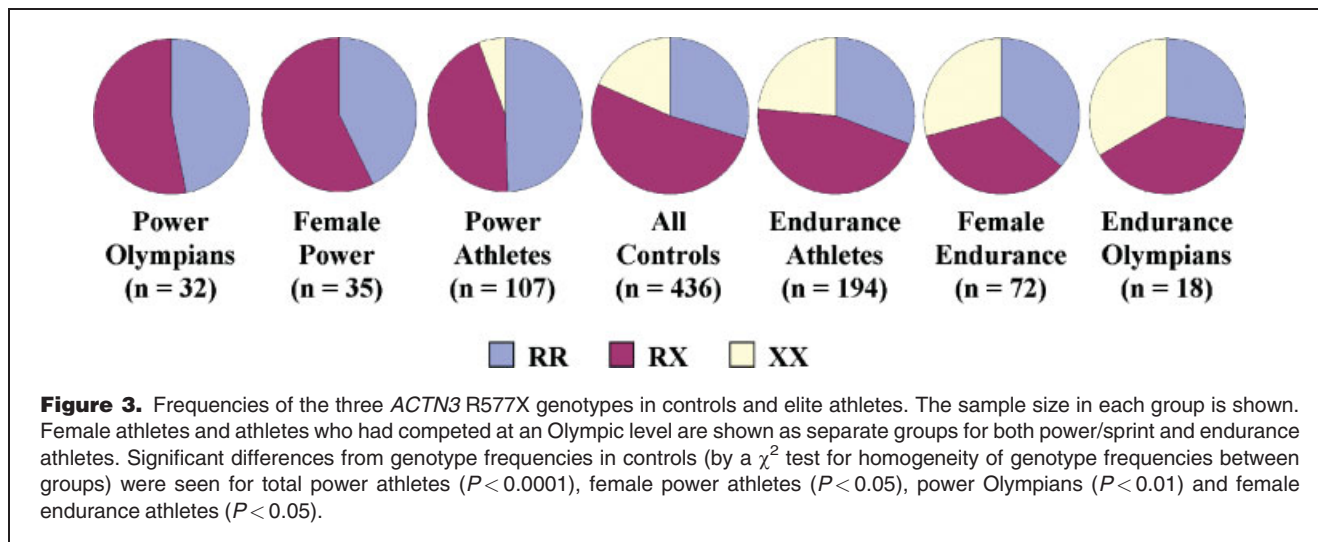

athletes than in controls, suggesting that the presence of  $\alpha$ -actinin-3 enhances performance in sprint-type activities. In contrast, we saw an apparent *increase* in the frequency of the 577XX genotype in endurance athletes, although this was only statistically significant in females. This suggests that the absence of  $\alpha$ -actinin-3 may actually be of some benefit for endurance performance. These trends were more extreme in Olympian athletes, and curiously also appeared to be more pronounced in females. It may be that the lower average levels of testosterone in female athletes makes variation in other parameters—such as *ACTN3* genotype—more important in determining athletic ability.

In sum, our results hint that the two *ACTN3* alleles may each provide advantages for different types of muscle performance—the R allele, which generates a functional  $\alpha$ -actinin-3 protein, appears to favour rapid, forceful muscle contraction, while the X allele may somehow provide an advantage for slow, efficient muscle performance. This possibility has obvious implications for the evolutionary history of the *ACTN3* gene in humans, which will be outlined in more detail below.

Genetic association studies have well-known limitations, and the results of a single association study should be interpreted cautiously until they have been replicated by other researchers.<sup>(65)</sup> However, the association certainly has biological plausibility. The R577X polymorphism has a demonstrable effect on the function of  $\alpha$ -actinin-3, with the 577X allele eliminating protein expression; in addition, the apparent benefit of the presence of functional  $\alpha$ -actinin-3 on sprint/power performance is consistent with the localisation of  $\alpha$ -actinin-3 to skeletal muscle fast-type fibres.

Nonetheless, to increase our confidence in the biological plausibility of the association, we plan to characterise the

precise mechanisms by which the loss of  $\alpha$ -actinin-3 influences skeletal muscle function. Several plausible mechanistic hypotheses can be devised based on the known functions of the sarcomeric  $\alpha$ -actinins (see above): for instance, (1) alterations to the contractile properties of the sarcomere in fast-type muscle fibres, (2) effects on muscle fibre type differentiation or hypertrophy via indirect interactions between  $\alpha$ -actinin-3 and signalling proteins such as calcineurin, (3) modification of the ability to resist and/or recover from exercise-induced muscle damage, or (4) changes to the metabolic profile of muscle fibres through altered interactions with metabolic enzymes such as fructose-1,6-bisphosphatase and phosphorylase. None of these scenarios are mutually exclusive, and it is likely that the actual mechanism is a combination of several such processes.

Of course, the theoretical plausibility of these hypotheses means very little in the absence of direct empirical support. We are currently exploring the function of  $\alpha$ -actinin-3 and the consequences of its loss using a variety of methods, including an *Actn3* knockout mouse, in vitro tissue culture models, and physiological analyses of human controls and athletes.

### Evolutionary implications

When we first identified the 577X null polymorphism,<sup>(12)</sup> we explored several possible explanations for its high frequency in the general human population. One distinct possibility was that *ACTN3* had become functionally redundant in humans and that, in the absence of any selective penalty against the inactivation of the *ACTN3* gene, the 577X allele may simply have reached its current frequency through random genetic drift. However, our genetic association results contradict the idea that *ACTN3* is completely functionally redundant in humans. We now believe that historical natural selection

probably underlies the high frequency of the 577X null allele in some human populations.

The possible association of the 577XX genotype with endurance performance, although relatively weak in our data set, provides some hints about the possible nature of this selection. If the 577X allele does somehow provide a benefit to performance in endurance activities, then positive selection for endurance performance may have increased its frequency during recent human evolution. Alternatively, the positively selected trait may be only indirectly related to endurance performance: for instance, if the absence of  $\alpha$ -actinin-3 affected the regulation of its metabolic enzyme binding partners (see above), and thus increased the metabolic efficiency of skeletal muscle, then 577X may constitute a “thrifty allele”<sup>(66)</sup> that has been selected for famine survival; the apparent positive effect on endurance performance could be merely a side effect of this selected trait. Our ongoing exploration of the phenotypic effects of  $\alpha$ -actinin-3 deficiency will hopefully throw some light on this intriguing question.

The varying frequency of the 577X allele in different ethnic groups suggests that any positive selection was relatively population-specific. However, the fact that the 577X allele is present at appreciable frequencies in all studied human populations suggests that the allele is relatively ancient, and that it has been maintained in the global human population over a long period of evolutionary time.

These lines of evidence lead us towards a tentative scenario for the evolutionary history of the 577X allele in humans. Following its ancient origin, the 577X allele may have been maintained at relatively low frequency in the human population for a long period of evolutionary time by some form of balancing selection, which occurs when two or more alleles at a locus each provide a selective advantage under different genetic or environmental conditions. During or following the emergence and migratory expansion of modern humans, the 577X allele may have been increased in frequency by positive natural selection in some human populations. This scenario, while currently entirely speculative, would explain the current population frequencies of the 577X allele, is consistent with the results of our association study, and has the further benefit of being experimentally testable. We are currently in the process of evaluating this model by gathering information on sequence variation in the region flanking the R577X polymorphism in a number of different human populations.

## Conclusion

The  $\alpha$ -actinin protein family has many advantages for research into molecular evolution.  $\alpha$ -actinin isoforms are unusually highly conserved in a wide variety of eukaryotes, allowing the examination of sequence changes that have occurred in diverse lineages over long periods of evolutionary time. The

functions and regulation of  $\alpha$ -actinin proteins have been characterised in depth in a number of these organisms—most notably in slime mould, fruit fly, chicken and human—permitting sequence changes to be mapped to functional differences in a number of cases. Importantly, two of the most-common mechanisms fuelling the generation of protein functional diversity, gene duplication and alternative splicing, have played major roles in the evolution of the  $\alpha$ -actinins, making this protein family a valuable case study from which we can learn about general processes guiding molecular evolution.

Human  $\alpha$ -actinin-3 provides an example of the intriguing findings that have emerged from research into the  $\alpha$ -actinin family. Our studies of  $\alpha$ -actinin-3 in humans were originally motivated by the possibility that mutations in the *ACTN3* gene might underlie muscle disease in humans. We did indeed discover a dramatic loss-of-function *ACTN3* mutation in humans but, as is so often the case in research, it was not what we expected. Far from causing muscle disease, the complete absence of  $\alpha$ -actinin-3 has no obvious phenotypic effect on the ~18% of the healthy human population homozygous for the R577X null mutation. Instead, we have shown that the loss of  $\alpha$ -actinin-3 may have a far more subtle effect, decreasing sprint and power performance but possibly aiding endurance activities. If correct, this may help to explain how a null allele for the *ACTN3* gene has managed to reach such high frequencies (~50%) in many human populations: we suspect that comparatively recent population-specific positive selection for endurance performance (or a related trait) in these groups has resulted in a rapid increase in the frequency of the 577X null allele.

Our group is now focusing on identifying and characterising the functions of human  $\alpha$ -actinin-3 and the phenotypic consequences of its absence, and determining the forces that have guided its recent evolution in humans. We are confident that this protein and its fellow family members will provide many more surprises over the coming years.

## References

1. Blanchard A, Ohanian V, Critchley D. 1989. The structure and function of  $\alpha$ -actinin. *J Muscle Res Cell Motil* 10:280–289.
2. Noegel A, Witke W, Schleicher M. 1987. Calcium-sensitive non-muscle  $\alpha$ -actinin contains EF-hand structures and highly conserved regions. *FEBS Lett* 221:391–396.
3. Fyrberg E, Kelly M, Ball E, Fyrberg C, Reedy MC. 1990. Molecular genetics of *Drosophila*  $\alpha$ -actinin: mutant alleles disrupt Z disc integrity and muscle insertions. *J Cell Biol* 110:1999–2011.
4. Barstead RJ, Kleiman L, Waterston RH. 1991. Cloning, sequencing, and mapping of an  $\alpha$ -actinin gene from the nematode *Caenorhabditis elegans*. *Cell Motil Cytoskeleton* 20:69–78.
5. Arimura C, Suzuki T, Yanagisawa M, Imamura M, Hamada Y, et al. 1988. Primary structure of chicken skeletal muscle and fibroblast  $\alpha$ -actinins deduced from cDNA sequences. *Eur J Biochem* 177:649–655.
6. Beggs AH, Byers TJ, Knoll JH, Boyce FM, Bruns GA, et al. 1992. Cloning and characterization of two human skeletal muscle  $\alpha$ -actinin genes located on chromosomes 1 and 11. *J Biol Chem* 267:9281–9288.
7. Honda K, Yamada T, Endo R, Ino Y, Gotoh M, et al. 1998. Actinin-4, a novel actin-bundling protein associated with cell motility and cancer invasion. *J Cell Biol* 140:1383–1393.



- Southby J, Gooding C, Smith CWJ. 1999. Polypyrimidine tract binding protein functions as a repressor to regulate alternative splicing of  $\alpha$ -actinin mutually exclusive exons. *Mol Cell Biol* 19:2699–2711.
- Kremerskothen J, Teber I, Wendholt D, Liedtke T, Böckers TM, et al. 2002. Brain-specific splicing of  $\alpha$ -actinin 1 mRNA. *Biochem Biophys Res Commun* 295:678–681.
- Mills M, Yang N, Weinberger R, Vander Woude DL et al. 2001. Differential expression of the actin-binding proteins,  $\alpha$ -actinin-2 and -3, in different species: implications for the evolution of functional redundancy. *Hum Mol Gen* 10:1335–1346.
- Squire JM. 1997. Architecture and function in the muscle sarcomere. *Curr Opin Struct Biol* 7:247–257.
- North KN, Yang N, Wattanasirichaigoon D, Mills M, Easteal S, et al. 1999. A common nonsense mutation results in  $\alpha$ -actinin-3 deficiency in the general population. *Nature Genet* 21:353–354.
- Yang N, MacArthur DG, Gulbin JP, Hahn AG, Beggs AH et al. 2003. *ACTN3* genotype is associated with human elite athletic performance. *Am J Hum Genet* 73:627–631.
- Sheterline P, Clayton JD, Sparrow JC. 1998. *Actin*. Oxford: Oxford University Press. p 272.
- Gimona M, Djirnovic-Carugo K, Kranewitter WJ, Winder SJ. 2002. Functional plasticity of CH domains. *FEBS Lett* 513:98–106.
- Virel A, Backman L. 2004. Molecular evolution and structure of  $\alpha$ -actinin. *Mol Biol Evol* (in press).
- Wu J-Q, Bähler J, Pringle JR. 2001. Roles of a fimbrin and an  $\alpha$ -actinin-like protein in fission yeast cell polarization and cytokinesis. *Mol Biol Cell* 12:1061–1077.
- Bricheux G, Coffe G, Pradel N, Brugerolle G. 1998. Evidence for an uncommon  $\alpha$ -actinin protein in *Trichomonas vaginalis*. *Mol Biochem Parasitol* 95:241–249.
- Thomas GH, Newbern EC, Korte CC, Bales MA, Muse SV et al. 1997. Intragenic duplication and divergence in the spectrin superfamily of proteins. *Mol Biol Evol* 14:1285–1295.
- Djinovic-Carugo K, Gautel M, Ylanne J, Young P. 2002. The spectrin repeat: a structural platform for cytoskeletal protein assemblies. *FEBS Lett* 513:119–123.
- Tang J, Taylor DW, Taylor KA. 2001. The three-dimensional structure of  $\alpha$ -actinin obtained by cryoelectron microscopy suggests a model for  $\text{Ca}^{2+}$ -dependent actin binding. *J Mol Biol* 310:845–858.
- Ohtsuka H, Yajima H, Maruyama K, Kimura S. 1997. The N-terminal Z repeat 5 of connectin/titin binds to the C-terminal region of  $\alpha$ -actinin. *Biochem Biophys Res Commun* 235:1–3.
- Flood G, Rowe AJ, Critchley DR, Gratzer WB. 1997. Further analysis of the role of spectrin repeat motifs in  $\alpha$ -actinin dimer formation. *Eur Biophys J* 25:431–435.
- Chan Y, Tong H-Q, Beggs AH, Kunkel LM. 1998. Human skeletal muscle-specific  $\alpha$ -actinin-2 and -3 isoforms form homodimers and heterodimers in vitro and in vivo. *Biochem Biophys Res Commun* 248:134–139.
- Kuhlman PA, Ellis J, Critchley DR, Bagshaw CR. 1994. The kinetics of the interaction between the actin-binding domain of  $\alpha$ -actinin and F-actin. *FEBS Lett* 339:297–301.
- Salmikangas P, Mykkanen OM, Gronholm M, Heiska L, Kere J, et al. 1999. Myotilin, a novel sarcomeric protein with two Ig-like domains, is encoded by a candidate gene for limb-girdle muscular dystrophy. *Hum Mol Gen* 8:1329–1336.
- Ohtsuka H, Yajima H, Maruyama K, Kimura S. 1997. Binding of the N-terminal 63 kDa portion of connectin/titin to  $\alpha$ -actinin as revealed by the yeast two-hybrid system. *FEBS Lett* 401:65–67.
- Nave R, Furst DO, Weber K. 1990. Interaction of  $\alpha$ -actinin and nebulin in vitro. Support for the existence of a fourth filament system in skeletal muscle. *FEBS Lett* 269:163–166.
- Papa I, Astier C, Kwiatek O, Raynaud F, Bonnal C et al. 1999. Alpha actinin-CapZ, and anchoring complex for thin filaments in Z-line. *J Muscle Res Cell Motil* 20:187–197.
- Hance JE, Fu SY, Watkins SC, Beggs AH, Michalak M. 1999.  $\alpha$ -Actinin-2 is a new component of the dystrophin-glycoprotein complex. *Arch Biochem Biophys* 365:216–222.
- Otey CA, Pavalko FM, Burrige K. 1990. An interaction between  $\alpha$ -actinin and the  $\beta_1$  integrin subunit in vitro. *J Cell Biol* 111:721–729.
- Faulkner G, Pallavicini A, Formentin E, Comelli A, Levoella C et al. 1999. ZASP: A new Z-band alternatively spliced PDZ-motif protein. *J Cell Biol* 146:465–475.
- Kotaka M, Kostin S, Ngai S, Chan K, Lau Y et al. 2000. Interaction of hCLIM1, an enigma family protein, with  $\alpha$ -actinin 2. *J Cell Biochem* 78:558–565.
- Zhou Q, Ruiz-Lozano P, Martone ME, Chen J. 1999. Cypher, a striated muscle-restricted PDZ and LIM domain-containing protein, binds to  $\alpha$ -actinin-2 and protein kinase C. *J Biol Chem* 274:19807–19813.
- Xia H, Winokur ST, Kuo WL, Altherr MR, Bredt DS. 1997. Actinin-associated LIM protein: Identification of a domain interaction between PDZ and spectrin-like repeat motifs. *J Cell Biol* 139:507–515.
- Pomies P, Louis HA, Beckerle MC. 1997. CRP1, a LIM domain protein implicated in muscle differentiation, interacts with  $\alpha$ -actinin. *J Cell Biol* 139:157–168.
- Burgueño J, Blake DJ, Benson MA, Tinsley CL, Esapa CT et al. 2003. The adenosine  $A_{2A}$  receptor interacts with the actin-binding protein  $\alpha$ -actinin. *J Biol Chem* 278:37545–37552.
- Dunah AW, Wyszynski M, Martin DM, Sheng M, Standaert DG. 2000.  $\alpha$ -actinin-2 in rat striatum: localization and interaction with NMDA glutamate receptor subunits. *Brain Res Mol Brain Res* 79:77–87.
- Sadeghi A, Doyle AD, Johnson BD. 2002. Regulation of the cardiac L-type  $\text{Ca}^{2+}$  channel by the actin-binding proteins  $\alpha$ -actinin and dystrophin. *Am J Physiol* 282:C1502–C1511.
- Cukovic D, Lu GWK, Wible B, Steele DF, Fedida D. 2001. A discrete amino terminal domain of Kv1.5 and Kv1.4 potassium channels interacts with the spectrin repeats of  $\alpha$ -actinin-2. *FEBS Lett* 498:87–92.
- Frey N, Richardson JA, Olson EN. 2000. Calsarcins, a novel family of sarcomeric calcineurin-binding proteins. *Proc Natl Acad Sci USA* 97:14632–14637.
- Frey N, Olson EN. 2002. Calsarcin-3, a novel skeletal muscle-specific member of the calsarcin family, interacts with multiple Z-disc proteins. *J Biol Chem* 277:13998–14004.
- Chin ER, Olson EN, Richardson JA, Yang Q, Humphries C et al. 1998. A calcineurin-dependent transcriptional pathway controls skeletal muscle fiber type. *Genes Dev* 12:2499–2509.
- Olson EN, Williams RS. 2000. Remodeling muscles with calcineurin. *BioEssays* 22:510–519.
- Chowrashi P, Mittal B, Sanger JM, Sanger JW. 2002. Amorphin is phosphorylase; phosphorylase is an alpha-actinin-binding protein. *Cell Motil Cytoskeleton* 53:125–135.
- Rakus D, Mamczur P, Gizak A, Dus D, Dzugaj A. 2003. Colocalization of muscle FBPase and muscle aldolase on both sides of the Z-line. *Biochem Biophys Res Commun* 311:294–299.
- Masters C. 1984. Interactions between glycolytic enzymes and components of the cytomatrix. *J Cell Biol* 99:222s–225s.
- Fukami K, Sawada N, Endo T, Takenawa T. 1996. Identification of a phosphatidylinositol 4,5-bisphosphate-binding site in chicken skeletal muscle  $\alpha$ -actinin. *J Biol Chem* 271:2646–2650.
- Young P, Gautel M. 2000. The interaction of titin and  $\alpha$ -actinin is controlled by a phospholipid-regulated intramolecular pseudoligand mechanism. *EMBO J* 19:6331–6340.
- Fukami K, Furuhashi K, Inagaki M, Endo T, Hatano S, et al. 1992. Requirement of phosphatidylinositol 4,5-bisphosphate for  $\alpha$ -actinin function. *Nature* 359:150–152.
- Fralely TS, Tran TC, Corgan AM, Nash CA, Hao J, et al. 2003. Phosphoinositide binding inhibits  $\alpha$ -actinin bundling activity. *J Biol Chem* 278:24039–24045.
- Nickel R, Jacobs T, Urban B, Scholze H, Bruhn H, et al. 2000. Two novel calcium-binding proteins from cytoplasmic granules of the protozoan parasite *Entamoeba histolytica*. *FEBS Lett* 486:112–116.
- Usmanova A, Astier C, Mejean C, Hubert F, Feinberg J, et al. 1998. Coevolution of actin and associated proteins: an  $\alpha$ -actinin-like protein in a cyanobacterium (*Spirulina platensis*). *Comp Biochem Physiol B* 120:693–700.
- Dixon JD, Forstner MRJ, Garcia DM. 2003. The  $\alpha$ -actinin gene family: a revised classification. *J Mol Evol* 56:1–10.
- Imamura M, Sakurai T, Ogawa Y, Ishikawa T, Goto K, et al. 1994. Molecular cloning of low- $\text{Ca}^{2+}$ -sensitive-type non-muscle  $\alpha$ -actinin. *Eur J Biochem* 223:395–401.

56. Parr T, Waites GT, Patel B, Millake DB, Critchley DR. 1992. A chick skeletal-muscle  $\alpha$ -actinin gene gives rise to two alternatively spliced isoforms which differ in the EF-hand  $\text{Ca}^{2+}$ -binding domain. *Eur J Biochem* 210:801–809.
57. Kobayashi R, Itoh H, Tashima Y. 1989.  $\alpha$ -Actinin expression during avian myogenesis in vivo. Evidence for the existence of an embryo-specific isoform of  $\alpha$ -actinin. *Eur J Biochem* 185:297–302.
58. Roullet EM, Fyrberg C, Fyrberg E. 1992. Perturbations of *Drosophila*  $\alpha$ -actinin cause muscle paralysis, weakness, and atrophy but do not confer obvious nonmuscle phenotypes. *J Cell Biol* 116:911–922.
59. Fyrberg C, Ketchum A, Ball E, Fyrberg E. 1998. Characterization of lethal *Drosophila melanogaster*  $\alpha$ -actinin mutants. *Biochem Genet* 36: 299–310.
60. Dubreuil RR, Wang P. 2002. Genetic analysis of the requirements for  $\alpha$ -actinin function. *J Muscle Res Cell Motil* 21:705–713.
61. Waites GT, Graham IR, Jackson P, Millake DB, Patel B, et al. 1992. Mutually exclusive splicing of calcium-binding domain exons in chick  $\alpha$ -actinin. *J Biol Chem* 267:6263–6271.
62. Lynch M, Force A. 2000. The probability of duplicate gene preservation by subfunctionalization. *Genetics* 154:459–473.
63. North KN, Beggs AH. 1996. Deficiency of a skeletal muscle isoform of  $\alpha$ -actinin ( $\alpha$ -actinin-3) in merosin-positive congenital muscular dystrophy. *Neuromuscular Disord* 6:229–235.
64. Vainzof M, Costa CS, Marie SK, Moreira ES, Reed U et al. 1997. Deficiency of  $\alpha$ -actinin-3 (*ACTN3*) occurs in different forms of muscular dystrophy. *Neuropediatrics* 28:223–228.
65. Ioannidis JPA, Ntzani EE, Trikalinos TA, Contopoulos-Ioannidis DG. 2001. Replication validity of genetic association studies. *Nature Genet* 29:306–309.
66. Neel JV. 1962. Diabetes mellitus: a “thrifty” genotype rendered detrimental by “progress”? *Am J Hum Genet* 14:353–362.